

# OPERATOR'S MANUAL

# DieHard®

## BATTERY CHARGER 50/15/2 Amp, 6/12 Volt, Manual 250 Amp ENGINE STARTER

Model No.  
200.71240



### CAUTION:

Read and follow all Safety  
Rules and Operating Instructions  
Before Every Use of this Product.

SAVE THESE INSTRUCTIONS.

---

Sears, Roebuck and Co., Hoffman Estates, IL 60179 U.S.A.

---

00-99-000853/0808

## TABLE OF CONTENTS

SECTION	PAGE
1. IMPORTANT SAFETY INSTRUCTIONS	1
2. PERSONAL PRECAUTIONS	2
3. PREPARING TO CHARGE	2
4. CHARGER LOCATION	3
5. DC CONNECTION PRECAUTIONS	3
6. WHEN BATTERY IS INSTALLED IN VEHICLE	3
7. WHEN BATTERY IS OUTSIDE OF VEHICLE	4
8. BATTERY CHARGING - AC CONNECTIONS	5
9. PARTS	7
10. PRODUCT FEATURES	8
11. ASSEMBLY INSTRUCTIONS	8
12. OPERATING INSTRUCTIONS	11
13. CALCULATING CHARGE TIME	12
14. USING THE ENGINE START FEATURE	14
15. MAINTENANCE INSTRUCTIONS	14
16. STORAGE INSTRUCTIONS	14
17. TROUBLESHOOTING	15

### DIEHARD THREE-YEAR FULL WARRANTY

When operated and maintained according to all supplied instructions, if this DieHard product fails due to a defect in material or workmanship within three years from the date of purchase, return it to any Sears store or other DieHard outlet in the United States for free replacement.

This warranty gives you specific legal rights, and you may also have other rights which vary from state to state.

SEARS, ROEBUCK AND CO., HOFFMAN ESTATES, IL 60179

FOR CUSTOMER ASSISTANCE OR REPLACEMENT PARTS, CALL  
TOLL-FREE FROM 7 AM TO 4:30 PM CT MONDAY THROUGH FRIDAY:  
1-800-SEARS-64 (1-800-732-7764)

**1. IMPORTANT SAFETY INSTRUCTIONS**

- 1.1** SAVE THESE INSTRUCTIONS - The DieHard model 71240 Manual Battery Charger, offers a wide range of features to accommodate the needs for home or light commercial use. This manual will show you how to use your charger safely and effectively. Please read and follow these instructions and precautions carefully as this manual contains important safety and operating instructions.
- 1.2** WARNING: This product contains chemicals known to the State of California to cause cancer and birth defects or other reproductive harm. Wash hands after handling.
- 1.3** Do not expose charger to rain or snow.
- 1.4** Use of an attachment not recommended or sold by the battery charger manufacturer may result in a risk of fire, electric shock or injury to persons.
- 1.5** To reduce the risk of damage to electric plug or cord, pull by the plug rather than the cord when disconnecting the charger.
- 1.6** An extension cord should not be used unless absolutely necessary. Use of an improper extension cord could result in a risk of fire and electric shock. If an extension cord must be used, make sure:
- That the pins on the plug of the extension cord are the same number, size and shape as those of the plug on the charger.
  - That the extension cord is properly wired and in good electrical condition and;
  - That the wire size is large enough for the AC ampere rating of the charger as specified in Table 8.3.
- 1.7** Do not operate the charger with a damaged cord or plug; take it to a qualified serviceman. (Call customer service at: 800-SEARS-64).
- 1.8** Do not operate the charger if it has received a sharp blow, been dropped or otherwise damaged in any way; take it to a qualified serviceman. (Call customer service at: 800-SEARS-64).
- 1.9** Do not disassemble the charger; take it to a qualified serviceman when service or repair is required. Incorrect reassembly may result in a risk of electric shock or fire. (Call customer service at: 800-SEARS-64).
- 1.10** To reduce the risk of electric shock, unplug the charger from the outlet before attempting any maintenance or cleaning. Turning off the controls will not reduce this risk.

## **WARNING – RISK OF EXPLOSIVE GASES.**

**WORKING IN THE VICINITY OF A LEAD-ACID BATTERY IS DANGEROUS. BATTERIES GENERATE EXPLOSIVE GASES DURING NORMAL BATTERY OPERATION. FOR THIS REASON, IT IS OF UTMOST IMPORTANCE THAT YOU FOLLOW THE INSTRUCTIONS EACH TIME YOU USE THE CHARGER.**

**TO REDUCE THE RISK OF BATTERY EXPLOSION, FOLLOW THESE INSTRUCTIONS AND THOSE PUBLISHED BY THE BATTERY MANUFACTURER AND THE MANUFACTURER OF ANY EQUIPMENT YOU INTEND TO USE IN THE VICINITY OF THE BATTERY. REVIEW THE CAUTIONARY MARKINGS ON THESE PRODUCTS AND ON THE ENGINE.**

## **2. PERSONAL PRECAUTIONS**

- 2.1** Consider having someone close enough by to come to your aid when you work near a lead-acid battery.
- 2.2** Have plenty of fresh water and soap nearby in case battery acid contacts your skin, clothing or eyes.
- 2.3** Wear complete eye protection and clothing protection. Avoid touching your eyes while working near the battery.
- 2.4** If battery acid contacts your skin or clothing, wash immediately with soap and water. If acid enters your eye, immediately flood the eye with cold running water for at least 10 minutes and get medical attention immediately.
- 2.5** NEVER smoke or allow a spark or flame in the vicinity of a battery or engine.
- 2.6** Be extra cautious to reduce the risk of dropping a metal tool onto the battery. It might spark or short-circuit the battery or other electrical part that may cause an explosion.
- 2.7** Remove personal metal items such as rings, bracelets, necklaces and watches when working with a lead-acid battery. A lead-acid battery can produce a short-circuit current high enough to weld a ring or the like to metal, causing a severe burn.
- 2.8** Use this charger for charging a LEAD-ACID battery only. It is not intended to supply power to a low voltage electrical system other than in a starter-motor application. Do not use this battery charger for charging dry-cell batteries that are commonly used with home appliances. These batteries may burst and cause injury to persons and damage to property.
- 2.9** NEVER charge a frozen battery.
- 2.10** **WARNING:** Pursuant to California Proposition 65, this product contains chemicals known to the State of California to cause cancer and birth defects or other reproductive harm.

### **3. PREPARING TO CHARGE**

- 3.1** If it is necessary to remove the battery from the vehicle to charge it, always remove the grounded terminal from the battery first. Make sure all of the accessories in the vehicle are off, so as not to cause an arc.
- 3.2** Be sure the area around the battery is well ventilated while the battery is being charged.
- 3.3** Clean the battery terminals. Be careful to keep corrosion from coming into contact with your eyes.
- 3.4** Add distilled water to each cell until the battery acid reaches the level specified by the battery manufacturer. Do not overfill. For a battery without removable cell caps, such as valve regulated lead-acid batteries, carefully follow the manufacturer's recharging instructions.
- 3.5** Study all of the battery manufacturer's specific precautions while charging and recommended rates of charge.
- 3.6** Determine the voltage of the battery by referring to the vehicle owner's manual and make sure that the output voltage selector switch is set to the correct voltage. If the charger has an adjustable charge rate, charge the battery at the lowest rate first.

### **4. CHARGER LOCATION**

- 4.1** Locate the charger as far away from the battery as the DC cables permit.
- 4.2** Never place the charger directly above the battery being charged; gases from the battery will corrode and damage the charger.
- 4.3** Never allow battery acid to drip onto the charger when reading the electrolyte specific gravity or filling the battery.
- 4.4** Do not operate the charger in a closed-in area or restrict the ventilation in any way.
- 4.5** Do not set a battery on top of the charger.

### **5. DC CONNECTION PRECAUTIONS**

- 5.1** Connect and disconnect the DC output clips only after setting all of the charger switches to the "off" position and removing the AC plug from the electrical outlet. Never allow the clips to touch each other.
- 5.2** Attach the clips to the battery and chassis, as indicated in steps 6.5, 6.6, and 7.2 thru 7.4.

**6. FOLLOW THESE STEPS WHEN BATTERY IS INSTALLED IN VEHICLE**

**A SPARK NEAR BATTERY MAY CAUSE BATTERY EXPLOSION. TO REDUCE RISK OF A SPARK NEAR BATTERY:**

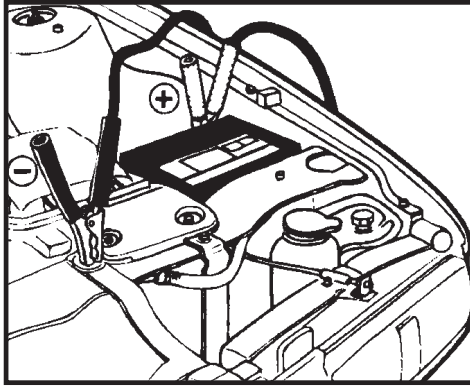

**NEGATIVE GROUNDED SYSTEM**

- 6.1** Position the AC and DC cables to reduce the risk of damage by the hood, door, or moving engine parts.
- 6.2** Stay clear of fan blades, belts, pulleys and other parts that can cause injury.
- 6.3** Check the polarity of the battery posts. The POSITIVE (POS, P, +) battery post usually has a larger diameter than the NEGATIVE (NEG, N, -) post.
- 6.4** Determine which post of the battery is grounded (connected) to the chassis. If the negative post is grounded to the chassis (as in most vehicles), see step 6.5. If the positive post is grounded to the chassis, see step 6.6.
- 6.5** For a negative-grounded vehicle, connect the POSITIVE (RED) clip from the battery charger to the POSITIVE (POS, P, +) ungrounded post of the battery. Connect the NEGATIVE (BLACK) clip to the vehicle chassis or engine block away from the battery. Do not connect the clip to the carburetor, fuel lines or sheet-metal body parts. Connect to a heavy gauge metal part of the frame or engine block.
- 6.6** For a positive-grounded vehicle, connect the NEGATIVE (BLACK) clip from the battery charger to the NEGATIVE (NEG, N, -) ungrounded post of the battery. Connect the POSITIVE (RED) clip to the vehicle chassis or engine block away from the battery. Do not connect the clip to the carburetor, fuel lines or sheet-metal body parts. Connect to a heavy gauge metal part of the frame or engine block.
- 6.7** When disconnecting the charger, turn all switches to off, disconnect the AC cord, remove the clip from the vehicle chassis, and then remove the clip from the battery terminal.
- 6.8** See OPERATING INSTRUCTIONS for length of charge information.

**7. FOLLOW THESE STEPS WHEN BATTERY IS OUTSIDE VEHICLE.**

**A SPARK NEAR THE BATTERY MAY CAUSE BATTERY EXPLOSION. TO REDUCE RISK OF A SPARK NEAR BATTERY:**

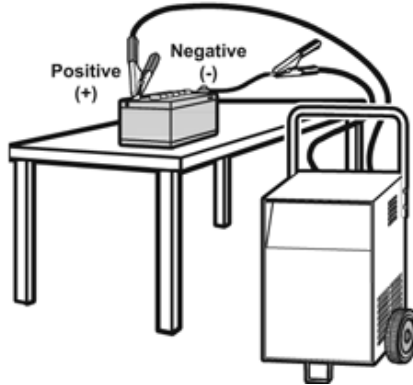

- 7.1 Check the polarity of the battery posts. The POSITIVE (POS, P, +) battery post usually has a larger diameter than the NEGATIVE (NEG, N, -) post.
- 7.2 Attach at least a 24-inch-long 6-gauge (AWG) insulated battery cable to the NEGATIVE (NEG, N, -) battery post.
- 7.3 Connect the POSITIVE (RED) charger clip to the POSITIVE (POS, P, +) post of the battery.
- 7.4 Position yourself and the free end of the cable you previously attached to the NEGATIVE (NEG, N, -) battery post as far away from the battery as possible – then connect the NEGATIVE (BLACK) charger clip to the free end of the cable.
- 7.5 Do not face the battery when making the final connection.
- 7.6 When disconnecting the charger, always do so in reverse sequence of the connecting procedure and break the first connection while as far away from the battery as practical.
- 7.7 A marine (boat) battery must be removed and charged on shore. To charge it onboard requires equipment specially designed for marine use.

## 8. BATTERY CHARGING - AC CONNECTIONS

### 8.1 For all grounded cord-connected battery chargers:

- **GROUNDING AND AC POWER CORD CONNECTION INSTRUCTIONS**
  - The charger should be grounded to reduce the risk of electric shock. The charger is equipped with an electric cord having an equipment-grounding conductor and a grounding plug. The plug must be plugged into an outlet that is properly installed and grounded in accordance with all local codes and ordinances.
- **DANGER** – Never alter the AC cord or plug provided – if it will not fit the outlet, have the proper outlet installed by a qualified electrician. An improper connection can result in a risk of an electric shock.

### 8.2 For all grounded, cord-connected battery chargers with an input rating less than 15-amperes and intended for use on a nominal 120-volt circuit:

- This battery charger is for use on a nominal 120-volt circuit, and has a grounding plug that looks like the plug illustrated in sketch A in Figure 8.4. A temporary adaptor, which looks like the adapter illustrated in sketches B and C, may be used to connect this plug to a two-pole receptacle as shown in sketch B if a properly grounded outlet is not available. The temporary adapter should be used only until a properly grounded outlet can be installed by a qualified electrician.
- **DANGER** – Before using an adapter as illustrated, be certain that the center screw of the outlet plate is grounded. The green-colored rigid ear or lug extending from the adapter must be connected to a properly grounded outlet – make certain it is grounded. If necessary, replace the original outlet cover plate screw with a longer screw that will secure the adapter ear or lug to the outlet cover plate and make a ground connection to the grounded outlet.



**8.3 Recommended minimum AWG size for extension cords for battery chargers:**

AC input rating, amperes <sup>a</sup>		AWG size of cord Length of cord, feet (m)			
At least	But less than	25 (7.6)	50 (15.2)	100 (30.5)	150 (45.6)
0	2	18	18	18	16
2	3	18	18	16	14
3	4	18	18	16	14
4	5	18	18	14	12
5	6	18	16	14	12
6	8	18	16	12	10
8	10	18	14	12	10
10	12	16	14	10	8
12	14	16	12	10	8
14	16	16	12	10	8
16	18	14	12	8	8
18	20	14	12	8	6

<sup>a</sup>If the input rating of a charger is given in watts rather than in amperes, the corresponding ampere rating is to be determined by dividing the wattage rating by the voltage rating – for example:  
 $1250 \text{ watts} / 125 \text{ volts} = 10 \text{ amperes}$

**8.4**

**Grounding Methods**

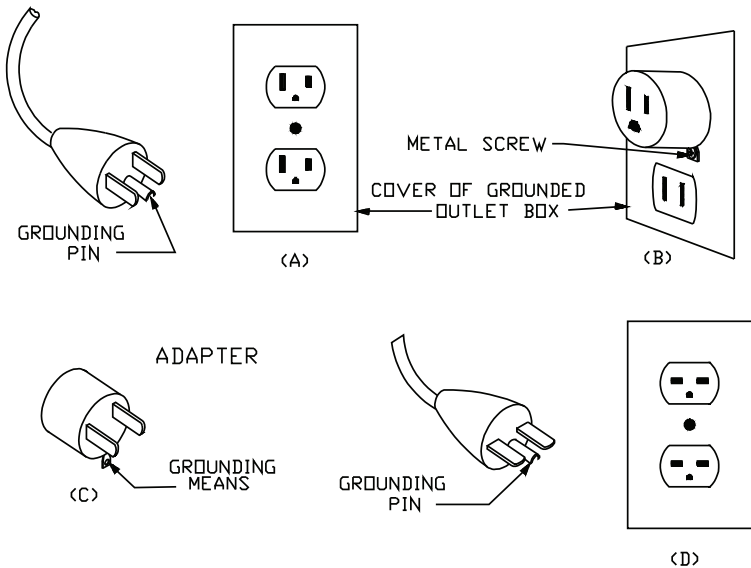

AA210

## 9. PRODUCT FEATURES

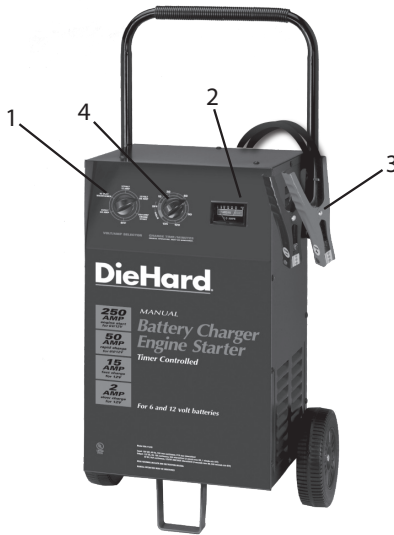

1. Volt Selector Switch
2. Ammeter
3. Clamps
4. Timer

In case of charger malfunction, **DO NOT** attempt to repair charger yourself. To arrange for charger repair, or information about customer replaceable parts, call 1-800-SEARS-65 (1-800-732-7764).

## 10. ASSEMBLY INSTRUCTIONS

It is important to fully assemble your charger before use. Follow these instructions for assembly:

PARTS	TOOLS NEEDED
Two, 10-32, thread cutting screws Four, 1/4-20, thread cutting screws Two wheels One axle Two axle caps Two axle brackets One handle One mounting foot	3/8" wrench (for mounting foot) 5/16" wrench (for wheels) Hammer Phillips screwdriver

### TO ATTACH THE AXLE ASSEMBLY:

- 10.1 Remove charger from packing materials and place upside down on a flat surface. Attach mounting foot and secure with the four, 1/4-20 thread cutting screws.

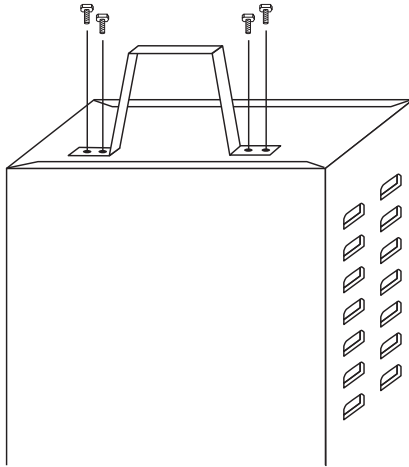

**10.2** Hold axle upright on floor or work surface. Then, using a hammer, tap one of the plastic axle caps onto the top end of the axle. Be sure to tap the axle cap on straight. Slide both wheels onto the axle with the axle caps facing each other.

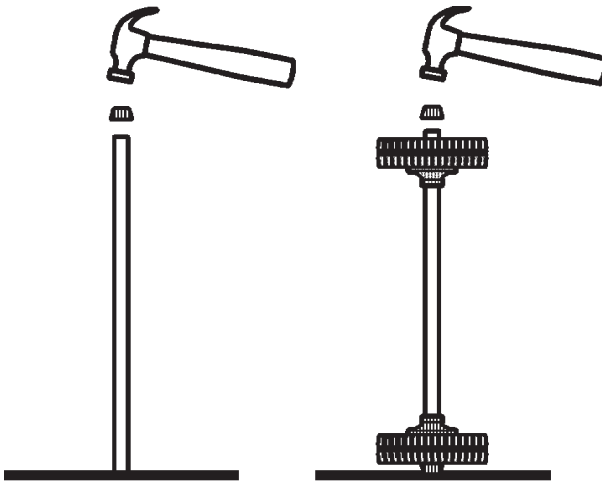

- 10.3** Place the charger on its side. Place one end of each bracket into slot, then place the axle assembly under each bracket. Fasten the other side of the brackets using the two, 10-32 screws provided.

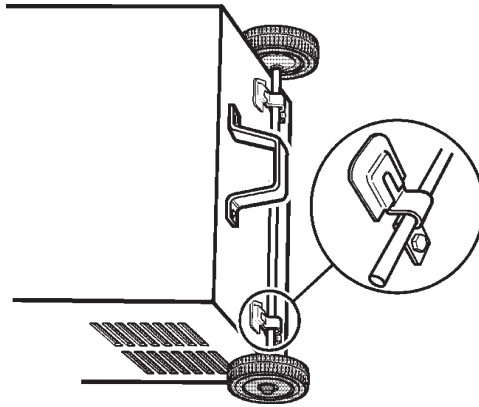

- 10.4** To Attach Handle:

Turn the charger right side up onto its foot and wheels. Remove the two top screws from each side of the charger. Align the handle so the screw holes are aligned with the screw holes on each side of the wheel charger. Attach the handle using the same screws.

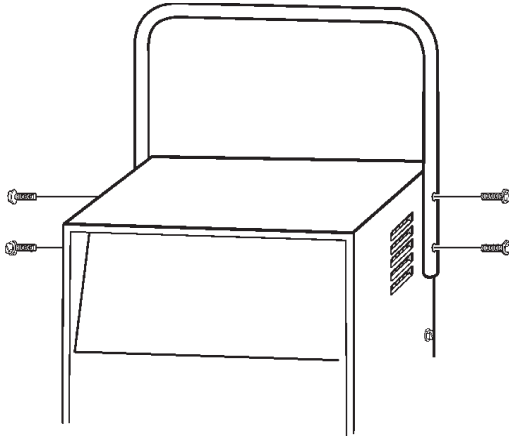

## 11. OPERATING INSTRUCTIONS

- 11.1 Follow steps in section 6 or 7 for hookup and disconnect instructions, and precautions.

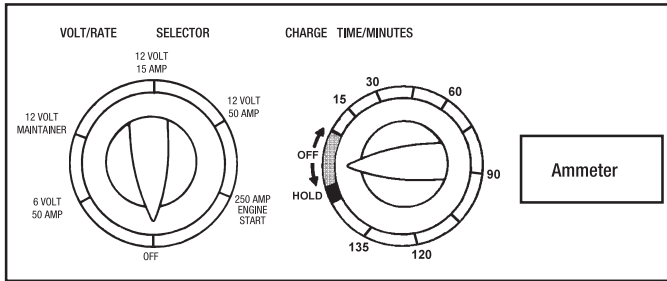

### SETTING THE CONTROLS

All controls for your charger are located on the front of the unit. Follow these instructions to obtain the accurate charge level for your battery.

- 11.2 **TIMER:** The main function of the timer is to prevent over charging while allowing the battery time to obtain a satisfactory charge. To properly set the timer, you must know the size of the battery in ampere hours or reserve capacity in minutes, and the state of charge. Often, the state of charge is not known, which is why the timer is limited to 2.25 hours. With the aid of a battery load tester, the state of charge can be obtained within a few seconds. For example, the average size automotive battery at a 50% state of charge, will require 1 to 1.5 hours of charging at the 50 amp rate to reach the full charge state. For the same battery with the timer set to its maximum of 2.25 hours, over charging will occur, but is unlikely to cause harm to the battery. When the charge state is unknown, start out with a timer setting of 1 hour or less.
- 11.3 **HOLD:** This function allows continuous operation. Use when charging for more than 2.25 hours (usually when the 2 amp charge rate is selected). Stop charging when the battery is fully charged.
- 11.4 **Rotary switch:** Use the rotary switch to select the charge rate or engine start setting required.
- 11.5 **Ammeter:** Indicates the amount of current measured in amperes that is being drawn by the battery. For example, in the 50 amp charge rate, a typical discharged battery will initially draw approximately 50 amps. As the battery continues to charge, current will taper to 15 to 20 amps at full charge. The Start area of the meter indicates a high rate of current being drawn from the charger. When cranking an engine, the starter motor draws upwards to 250-300 amps. The meter needle will be at the extreme right side of the start area. Sometimes, for the first few minutes of its charge, the battery will draw more than 50 amps; in this case, the needle may be within, but not all the way over, to the right side of the start area. The 2 amp charge rate may not indicate activity on the meter. The meter does not have the resolution to display this low rate.

## 12. CALCULATING CHARGE TIME

### 12.1 The Chart Method

Use the following table to more accurately determine the time it will take to bring a battery to full charge. First, identify where your battery fits into the chart.

- Small batteries — motorcycles, garden tractors, etc. — are usually rated in Ampere Hours (**AH**). For example: 6 to 12 AH, or 12 to 32 AH.
- Batteries in cars and smaller trucks are usually rated in Reserve Capacity (**RC**), Cold-Cranking Amps (**CCA**), or both.
- Marine or deep-cycle batteries are usually rated in Reserve Capacity (**RC**).
- **NR** means that the charger setting is **NOT RECOMMENDED**.

Find your battery's rating on the chart below and note the charge time given for each charger setting. The times given are for batteries with a **50-percent charge rate** prior to recharging. Add more time for severely discharged batteries.

BATTERY SIZE/RATING			CHARGE RATE/ CHARGING TIME - HOURS	
			2 AMP	50 AMP
SMALL BATTERIES	Motorcycle, garden, tractor, etc.	6 - 12 AH	2 - 4	NR
		12 - 32 AH	4 - 10	NR
CAR/TRUCKS	200 - 315 CCA	40 - 60 RC	11 - 14	30 to 45 min.
	315 - 550 CCA	60 - 85 RC	14 - 18	45 min - 1 hour
	550 - 1000 CCA	85 - 190 RC	18 - 35	1 - 2 hours
MARINE/DEEP CYCLE		80 RC	18	NR
		140 RC	27	NR
		160 RC	30	NR
		180 RC	33	NR

## 12.2 The Hydrometer or Electronic Method

To find the time needed to fully charge your battery, determine the battery's charge level with a hydrometer or electronic Percent-of-Charge Tester. The following table will help you convert hydrometer readings to percent of charge values.

SPECIFIC GRAVITY	PERCENT OF CHARGE	PERCENT OF CHARGE NEEDED
1.265	100%	0%
1.225	75%	25%
1.155	25%	75%
1.120	0%	100%

When you know the percent of charge and the Amp Hour (AH) rating of your battery, you can calculate the approximate time needed to bring your battery to a full charge.

To **convert** Reserve Capacity to Amp Hours, divide Reserve Capacity by 2, and add 16:

$$\text{Amp Hours} = \frac{\text{Reserve Capacity}}{2} + 16$$

**NOTE:** The Reserve Capacity can be obtained from the battery specification sheet or the owner's manual.

### To calculate time needed for a charge:

- Find the percent of **charge needed**. (A battery at 50 percent charge that will be charged to 100 percent needs another 50 percent (.50)).
- Multiply the Amp Hour rating by the charge needed (.50) and divide by the charger setting (2 or 10 amps).
- Multiply the result by 1.25 and you'll have the approximate time needed, in hours, to bring the battery to full charge.
- Add one additional hour for a deep-cycle battery.

### Example:

$$\frac{\text{Amp Hour Rating} \times \text{charge needed}}{\text{Charger Setting}} \times 1.25 = \text{hours of charge}$$

$$\frac{100 \text{ (AH Rating)} \times .50 \text{ (charge needed)}}{50 \text{ (Charger Setting)}} \times 1.25 = 6.25 \text{ hours}$$

$$\frac{100 \times .50}{50} = 1.25 \times 1.25 = 1.5625$$

You will need to charge your 100-Ampere Hour Battery for approximately 1 1/2 hours at the 50-Amp charge rate using the above example.

### **13. USING THE ENGINE START FEATURE**

- 13.1** Set charge rate switch and timer to OFF positions.
- 13.2** With the charger unplugged from the AC outlet, connect the charger to the battery following instructions given in section 6 or 7.
- 13.3** Plug the charger AC power cord into the AC outlet, then move timer from OFF to HOLD position.
- 13.4** Set the charge rate switch to the engine start position and then crank the engine. Follow the duty cycle of your charger for proper ON / OFF times. During extremely cold weather or when the battery is severely exhausted, charge the battery for about 5 minutes before cranking the engine.
- 13.5** If the engine fails to start, charge the battery for 5 more minutes before attempting to crank the engine again.
- 13.6** After the engine starts, move the charge rate switch to OFF and unplug the AC power cord from the outlet before disconnecting DC clips.

### **14. MAINTENANCE INSTRUCTIONS**

- 14.1** Before performing maintenance, unplug and disconnect battery charger (see sections 6.7 or 7.6).
- 14.2** After use, use a dry cloth to wipe all battery corrosion and other dirt or oil from terminals, cords, and the charger case.
- 14.3** Through routine maintenance, ensure all user installed parts are secured.

### **15. STORAGE INSTRUCTIONS**

- 15.1** Store charger unplugged, in an upright condition. Cord will still conduct electricity until it is unplugged from outlet.
- 15.2** Store inside, in a dry, cool place (unless you're using an on-board Marine Charger ).
- 15.3** Do not store clips on handle, clipped together, on or around metal, or clipped to cables.



## 16. TROUBLESHOOTING

PROBLEM	POSSIBLE CAUSE	SOLUTION/REASONS
No reading on the ammeter.	Clamps are not making a good connection.  2-amp charge rate is being used.	Check for poor connections to battery and frame. Make sure connecting points are clean.  Ammeter may show no activity at the 2-amp charge rate.
No reading on ammeter. Fan inside wheel charger appears to not be working.	No power at receptacle.  AC cord and/or extension cord is loose.	Check for open fuse or circuit breaker supplying AC outlet.  Check power cord and extension cord for loose fitting plug.
Circuit breaker in charger cycles on and off with a clicking sound.	Shorted battery clamps.  Shorted battery.  Charger leads reversed.  Volt/Amp Selector Switch set to the START position.	Circuit breaker cycles when current draw is too high. Separate the clamps. Check for worn cables and replace if needed.  Have battery tested by a Sears or other qualified service dealer.  Correct Connections.  Correct Volt/Amp Selector setting.
Short start cycle when cranking engine.	Drawing more than 250 amps for a period of 3 seconds or less.  Failure to wait for 4 minutes (240 seconds) between cranks.	Crank time varies with the amount of current drawn. If cranking draws more than 250 amps, crank time may be less than 3 seconds.  Wait 4 minutes before next crank.
Ammeter reads less than selected charge rate when charging a discharged battery.	Extension cord too long or wire gauge too small.  Weak cell or sulfated plate in battery.  Battery is only partially discharged.	Use shorter or heavier gauge extension cord.  Sulfated battery will eventually take a normal charge if left connected. If the battery will not take a charge, have it tested by a Sears or other qualified service dealer.  Continue charging battery.
Charger makes a loud buzz or hum.	Transformer laminations vibrate (buzz).  Shorted diode (hum).	Continue charging. Buzz is not abnormal.  Have charger tested by a Sears or other qualified service dealer.

**If the above solutions do not eliminate the problem  
call toll-free from anywhere in the U.S.A.  
1-800-SEARS-64 (1-800-732-7764)**

**7 AM to 4:30 PM Central Time Monday through Friday**



